

Plasma Arc Cutter

I. Competencies

Given a properly adjusted plasma arc cutter, accessories, instruction and demonstration of use, each student will be able to:

- A. Identify the major parts of the plasma arc cutter.
- B. Pass a written test on safety and operating procedures of the plasma arc cutter with 100 percent accuracy.
- C. Demonstrate ability to use the plasma arc cutter, following suggested safety rules and correct operation procedures.

II. Instructional Materials and Procedures

A. Identification of Basic Plasma Arc Cutter Parts.

- | | |
|------------------------------|------------------------------|
| 1. Control Panel | 7. Electrode |
| 2. Access Panel | 8. Gas Distributor |
| 3. Torch Heads | 9. Constricting Nozzle (Tip) |
| 4. Regulator/Filter | 10. Shielding Cup |
| 5. Filter Assembly (2 stage) | 11. Ground Clamp |
| 6. Torch Head Assembly | |

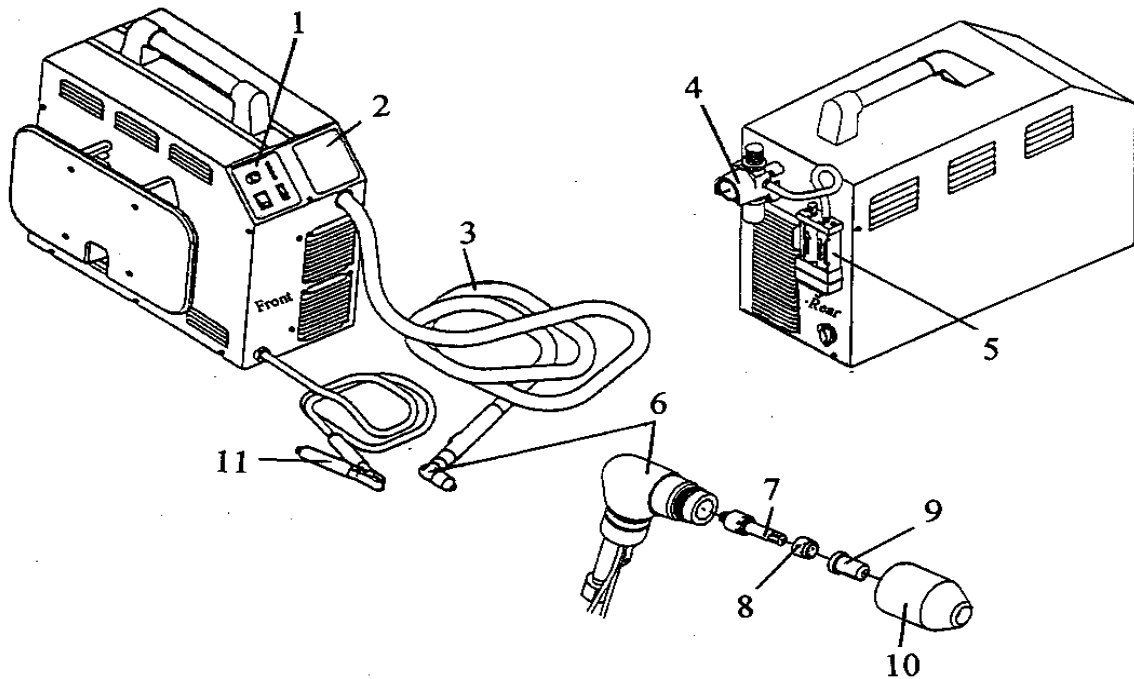

B. Plasma Arc Cutter Safety

1. Wear protective clothing when using the plasma arc cutter. Clothing should be wool or cotton, long sleeves, leather shoes (High Top), gauntlet gloves and leather apron.
2. Never wear synthetic clothing when using the plasma arc cutter, many synthetics are highly flammable.
3. Always wear industrial quality eye protection a #5 shaded lens is minimum for the plasma arc cutter process. The shaded lens needed to adequately protect the eyes varies by the thickness of the metal being cut and the intensity of the arc required to make the cut. Follow the manufacturer's recommendation for selecting an appropriate shaded lens for given plasma arc cut.
4. Make sure that work area is well ventilated when using the plasma arc cutter. The plasma arc cutter process generates lots of fumes and therefore must be well ventilated.
5. The operator should position himself/herself so there will be minimum exposure to fumes during the cutting process.
6. Fumes from the following metals can be toxic and in some cases fatal. Avoid cutting these metals with the plasma arc cutter in the school setting. When encountered in the industrial setting special care must be taken to avoid breathing fumes given off by these metals:

Antimony	Chromium	Mercury
Arsenic	Cobalt	Nickel
Barium	Copper	Selenium
Beryllium	Lead	Silver
Cadmium	Manganese	Vanadium

7. Use a cutting table which has a down draft to capture fumes. A cutting table with water filtration is also recommended for plasma arc cutting.
8. Never use the plasma arc cutter in areas where combustible or explosive gases or materials are located.
9. Chlorinated solvents and cleaner vapors in the presence of plasma arc cutter generates a toxic phosgene gas. Avoid plasma arc cutting use in areas which house chlorinated solvents and cleaners.

10. Never touch any parts on the plasma arc cutter that are electrically connected. The plasma arc cutter uses high amperage and produces high voltage which can cause severe or fatal electrical shock.
11. Disconnect the electrical power before performing any service or repair on the plasma arc cutter.
12. Do not use the plasma arc cutter to cut on containers that have held combustible materials.
13. Hydrogen gas may be formed and trapped when cutting aluminum in the presence of water. Trapped hydrogen gas in the presence of an arc will ignite and explode, make sure fumes are well ventilated when cutting aluminum.
14. Hearing protection should be worn when operating the plasma arc cutter.
15. Make sure that others in the work area are protected from the plasma arc cutter arc rays and fumes.
16. Use pliers or tongs to handle hot metals cut by the plasma arc cutter. Cool and store hot metal before leaving the work area.

C. Plasma Arc Cutter Operating Procedures

1. To activate the plasma arc cutter make sure the air pressure is sufficiently around 70 p.s.i. for most plasma arc cutter units and the ground clamp is attached to the work piece.
2. Turn the plasma arc cutter on and adjust the amperage the manufacturers specifications for the thickness of metal to be cut.
3. Position the shielding cup over the metal, press the igniter button and allow the arc to become established. Next, move the arc over the cut line and make the cut.
4. The thicker the metal the slower the travel speed must be to get a good cut and vice versa. The quality of the cut usually decreases as the metal thickness increases and the travel speed decreases.
5. A guide bar may be used to help achieve good straight cuts.

6. The shielding cup and constricting nozzle should be held approximately 1/8" to 1/4" above the metal being cut. The operator should avoid dragging the constricting nozzle and shielding cup on the metal when making the cut unless they are specifically designed to touch the base metal while cutting.
7. Always make cuts on the waste side of the cut line.
8. Avoid cutting with the plasma arc cutter in damp or wet locations. The hazards of electrical shock greatly increased.
9. If plasma arc cutting over an open barrel with a grate be aware that the fume plume will be directed back toward the operator. Avoid this condition if at all possible, otherwise limit the exposure to fumes to short duration's.
10. Cuts with the plasma arc cutter may be made by moving forward, backward, or sideways. Determine which direction is easiest for you and use that procedure as often as possible.
11. Always move the plasma arc cutter (PAC) as fast as possible when making a cut. This increases time efficiency , improves the cut quality, and reduces the build up of dross.
12. Compressed air used in plasma arc cutter should be dry or the cutter will not yield a quality cut or it not cut at all. An auxiliary air filter may be place in the compressed air line to condition the air for a plasma arc cutter.
13. Always turn the plasma arc cutter off before laying the torch down and leaving the work area.
14. If the quality of the cut deteriorates to an unacceptable level either the constricting nozzle, the electrode, or both may need to be changed. The electrode on most plasma arc cutter will have a life of about twice the life of the constriction nozzle. Keep a supply of constricting nozzles and electrodes on hand as they deteriorate quickly during continuous use. Turn the plasma arc cutter off to put on replacement parts.
15. Keep the plasma arc cutter torch leads and ground lead stored so they will not be cut or damaged when not in use.

III. Written Test

Plasma Arc Cutter Safety and Operation Test

Name _____ Date _____ Class _____

Multiple Choice - Place the letter of the most correct answer on the answer sheet.

1. Why should synthetic clothes never be worn when operating the plasma arc cutter?
 - a. They are too expensive.
 - b. They create an electrical shock hazard.
 - c. They are highly flammable.
 - d. They are energy absorbing which creates a health hazard.

2. The minimum shaded lens that should be used for plasma arc cutting is _____.
 - a. 3
 - b. 5
 - c. 8
 - d. 10

3. The fume plume for plasma arc cutting is _____.
 - a. minimal.
 - b. about like oxy-fuel gas welding.
 - c. large and needs to be ventilated well.
 - d. light and dissipates quickly.

4. Which one of the following metals does not give off a toxic fume?
 - a. Carbon steel
 - b. Beryllium
 - c. Copper
 - d. Nickel

5. Avoid using the plasma arc cutter in _____.
 - a. outside locations.
 - b. interior locations.
 - c. shops with concrete floors.
 - d. area where combustible gases are stored.

6. What combustible gas is generated when aluminum is cut with the plasma arc cutter in the presence of water or moisture?
 - a. Propane
 - b. Methane
 - c. Acetylene
 - d. Hydrogen

7. What personal protective equipment should be worn when operating a plasma arc cutter?
 - a. Shaded lens
 - b. Shaded lens, and hearing protection.
 - c. Shaded lens, hearing protection, and gloves.
 - d. Shaded lens, hearing protection, gloves, and leather apron.

8. If plasma arc cutting takes place in the presence of vapors from chlorinated solvents and cleaners what may happen?
 - a. A toxic phosgene gas may be generated.
 - b. A combustible gas will be formed.
 - c. Hydrogen gas may be generated and cause an explosion.
 - d. Nothing- there is no danger cutting in this environment.

9. Electrical shock is more of possibility in the plasma arc cutting process than with arc welding process because of _____.
 - a. the type of equipment used.
 - b. the high voltage and amperage used.
 - c. the high arc temperatures.
 - d. the plasma gases used in the cutting process.

10. What approximate air pressure must be present to activate most plasma arc cutters?
 - a. 40 p.s.i.
 - b. 50 p.s.i.
 - c. 60 p.s.i.
 - d. 70 p.s.i.

11. What happens to the travel speed of the plasma arc cutting machine when the metal being cut is thick?
- It must be slowed down.
 - It must be speeded up.
 - Travel speed does not change.
 - Travel speed is a function of the operator's ability.
12. How can the plasma arc cutter operator be assured of getting good straight cuts?
- Move quickly when making the cut.
 - Move slowly when making the cut.
 - Use a straight edge.
 - Increase the amperage slightly to assure complete melting of the edges along the kerf.
13. The constricting nozzle should be held about _____ above the metal being cut when using the plasma arc cutter.
- 1 inch
 - 3/4 inch
 - 1/2 inch
 - 1/4 inch
14. Avoid cutting with the plasma arc cutter in _____ locations.
- extremely dry
 - damp or wet
 - extremely hot
 - cold
15. Cuts with the plasma arc cutter should be made with the torch moving _____.
- forward.
 - backward.
 - side ways.
 - any of these.

16. If the plasma arc cutter is moved fast in a cut it will _____.

- a. improve the cut quality.
- b. reduce dross build up.
- c. improve time efficiency.
- d. all of these.

17. If the quality of the cut deteriorates with the plasma arc cutter what has most likely happened?

- a. The shield cup needs replacing.
- b. The constricting nozzle needs replacing.
- c. the electrode needs replacing.
- d. both b and c

IV. Performance Test for the Plasma Arc Cutter

Name _____

The student performs the following while operating the plasma arc cutter.

	Yes	No	N/A
1. The appropriate shaded lens is used for the plasma arc cutting process.	___	___	___
2. Hearing protectors, leather apron and gloves are worn when operating the plasma arc cutter.	___	___	___
3. Flammable materials are removed from the plasma arc cutting area?	___	___	___
4. The cutting area is well ventilated.	___	___	___
5. The plasma arc cutter is properly adjusted to make the cut.	___	___	___
6. The constricting nozzle and shielding cup are at the correct distance above the base metal.	___	___	___
7. The speed of travel is correct.	___	___	___
8. The student can remove and replace the electrode and constricting nozzle on the plasma arc cutter.	___	___	___
9. The student can safely control the plasma arc cutter and perform satisfactory cutting.	___	___	___

I do hereby certify that _____ has satisfactorily demonstrated ability to operate the plasma arc cutter by passing this performance test.

Student Date Teacher Date

Plasma Arc Cutter Parts Identification Test

Name _____

Match the number of each plasma arc cutter part with the correct part name.

- | | |
|-------------------------------------|-------------------------------------|
| ___ A. Control Panel | ___ G. Electrode |
| ___ B. Access Panel | ___ H. Gas Distributor |
| ___ C. Torch Heads | ___ I. Constricting
Nozzle (Tip) |
| ___ D. Regulator/Filter | ___ J. Shielding Cup |
| ___ E. Filter Assembly
(2 stage) | ___ K. Ground Clamp |
| ___ F. Torch Head Assembly | |

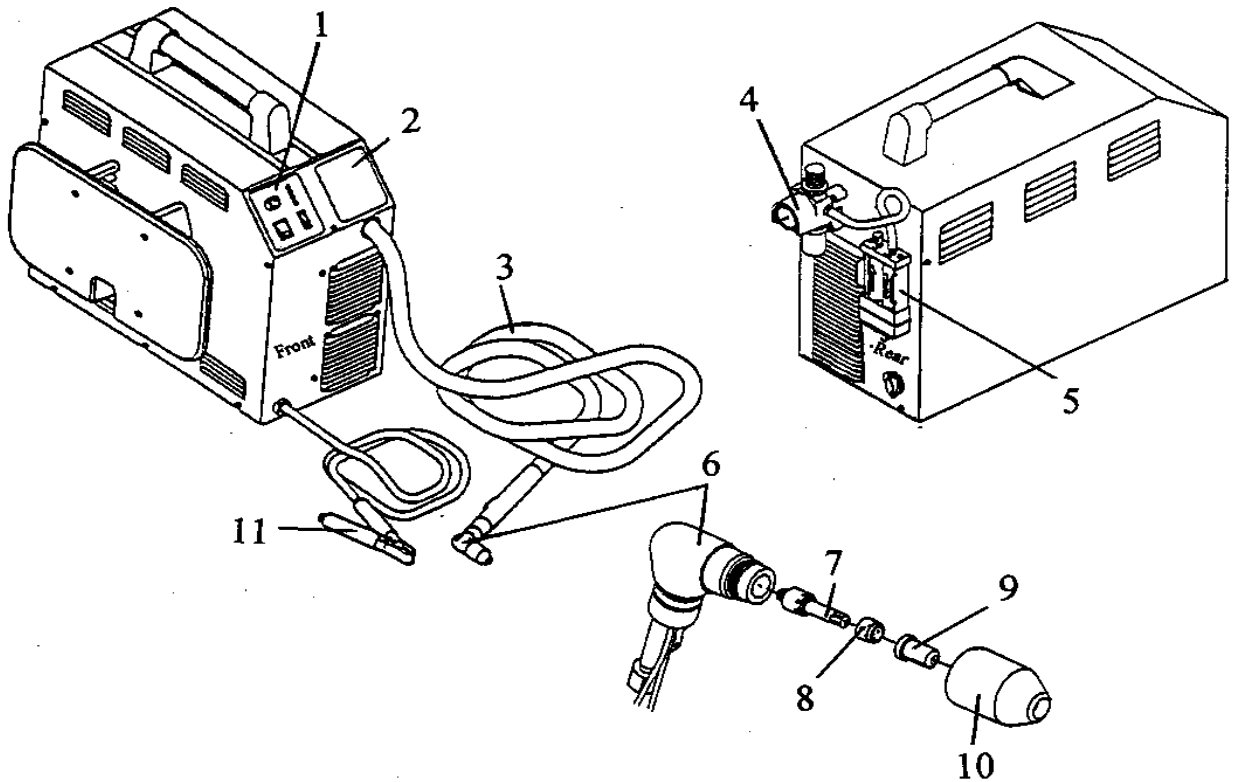

Plasma Arc Cutter

